

## Kraftstoff-Tauchrohrgeber Kunststoff

## Tubular Fuel Level Sender Plastic

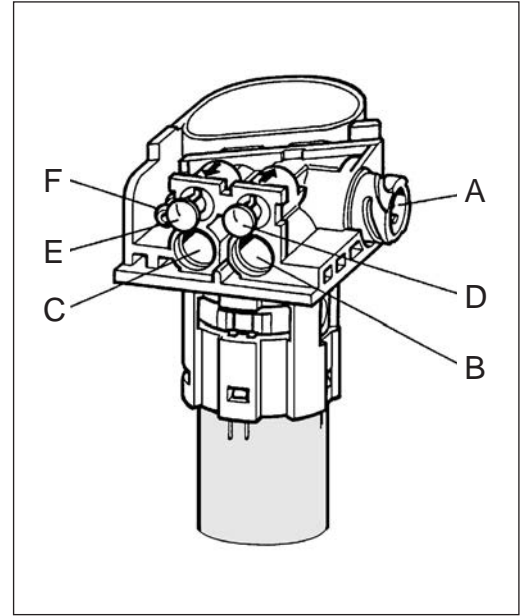

Anschlüsse / Connectors		
A	Bajonettstecker, DIN 72585 (A1-2.1RG/K1)	Bayonet connector, DIN 72585 (A1-2.1RG/K1)
B	Rücklauf	Outlet
C	Vorlauf	Inlet
D	Rücklauf externe Heizung oder Druckausgleich zu anderem Tank	External heater outlet or pressure equalization with another tank
E	Vorlauf externe Heizung	External heater inlet
F	Entlüftung über Ventile	Air outlet via valve

### Technische Daten:

Nennspannung: 6 V bis 24 V (massiefrei)  
 Widerstand: 3 Ω (Leer) bis 180 Ω (Voll)  
 Strom: 20 mA bis 120 mA  
 Betriebstemperatur: - 30 °C bis + 70 °C  
 Be-/Entlüftungsventile:

Überdruck bis 200 mbar entspricht einer Durchflussmenge von weniger als 25 g/min Dieseldieselkraftstoff;  
 Überdruck von mehr als 300 mbar entspricht einer Durchflussmenge von mehr als 25 g/min Dieseldieselkraftstoff;  
 Unterdruck von 10 bis 20 mbar entspricht einer Durchflussmenge von mehr als 1,75 l/h Dieseldieselkraftstoff

Lebensdauer: 1 Mio. Hubwechsel voll/leer in Dieseldieselkraftstoff

Schwingungsprüfung:  
 20 bis 50 Hz PSD = 0,03 g<sup>2</sup>/Hz  
 50 bis 1000 Hz PSD = - 6 dB/Okt  
 8h/Achsrichtung (PSD = power spectral density)

Material:  
 Flansch, Geberkörper: POM  
 Kraftstoffrohr: PA11 oder PA12  
 Schwimmer: NBR

### Technical Data:

Rated voltage: 6 V to 24 V (insulated return)  
 Resistor: 3 Ω (Empty) to 180 Ω (Full)  
 Current: 20 mA to 120 mA  
 Operating temperature: - 30 °C to + 70 °C  
 Ventilation or bleeder values:

Positive pressure up to 200 mbar corresponds to flow rate of less than 25 g/min diesel fuel.  
 Positive pressure greater than 300 mbar corresponds to flow rate of more than 25 g/min diesel fuel.  
 Negative pressure of 10–20 mbar corresponds to flow rate of more than 1.75 l/h diesel fuel.

Service Life: 1 Mio. travel changes full/empty in Dieseldiesel fuel

Vibrational test:  
 20 to 50 Hz PSD = 0.03 g<sup>2</sup>/Hz  
 50 to 1000 Hz PSD = - 6 dB/Oct.  
 8h/axle line (PSD = power spectral density)

Material:  
 Flange, sensor body: POM  
 Fuel tube: PA11 or PA12  
 Float: NBR

# Kraftstoff-Tauchrohrgeber Kunststoff

Abmaße [mm]

# Tubular Fuel Level Sender Plastic

Dimensions [mm]

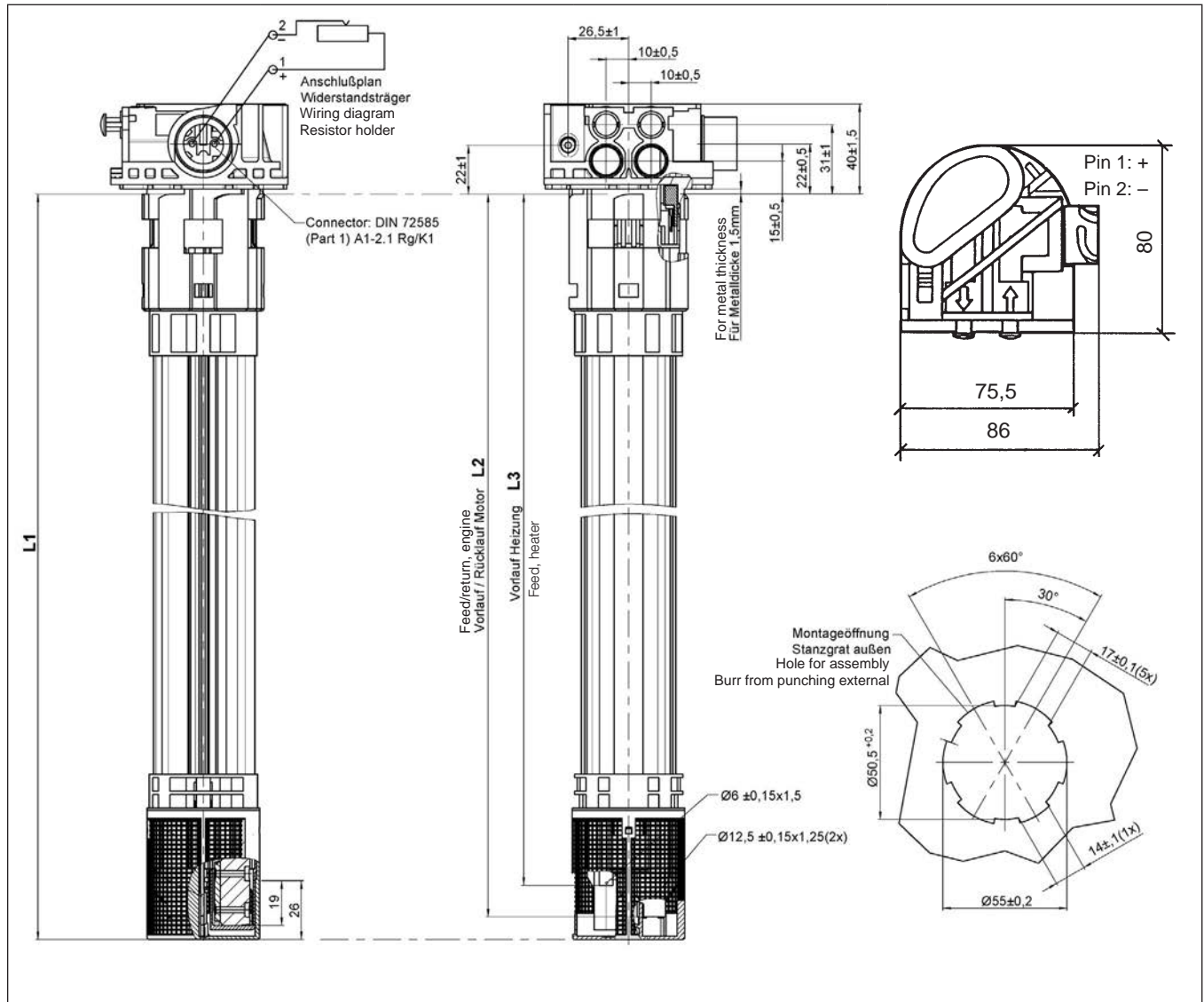

Artikelnummer Order Number	Gesamtlänge L1 Overall length L1	Länge bis Vorlaufleitung L2 Length to inlet tube, L2	Länge bis Heizungsleitung L3 Length to heating tube, L3
	[mm]	[mm]	[mm]
A2C59510128	455 ±2	446 <sup>+2.5</sup> <sub>-3.5</sub>	432 <sup>+2.5</sup> <sub>-3.5</sub>
A2C59510129	544 ±2	535 <sup>+2.5</sup> <sub>-3.5</sub>	519 <sup>+2.5</sup> <sub>-3.5</sub>
A2C59510130	672 ±2	663 <sup>+2.5</sup> <sub>-3.5</sub>	654 <sup>+2.5</sup> <sub>-3.5</sub>
Voll / Full: 180 Ω ±3.7 Ω; Leer / Empty: 3 Ω ±1.05 Ω			

**Kraftstoff-Tauchrohrgeber  
Metall Standard  
Flanschlochkreis Ø 54 mm**

**Tubular Fuel Level Sensor  
Metal Standard  
Flange bolt hole circle dia. 54 mm**

Abmaße / Dimensions (mm):

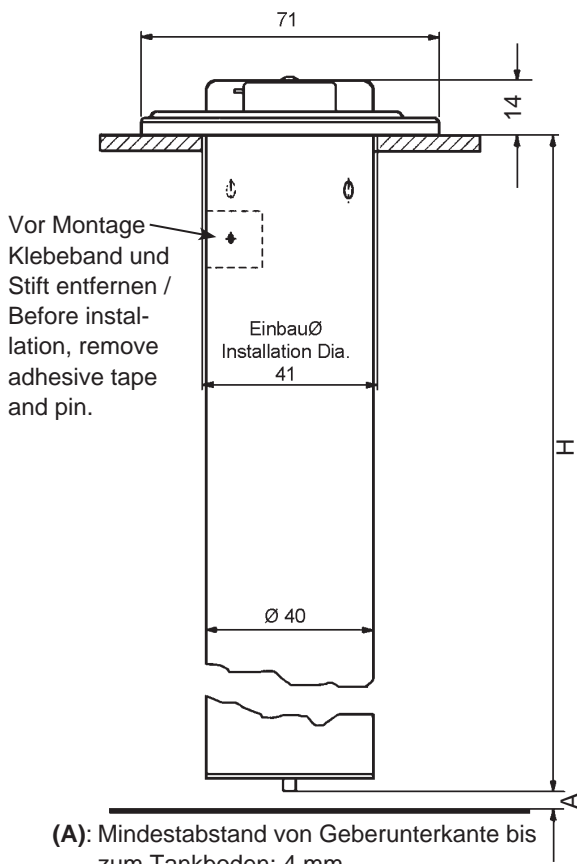

(A): Mindestabstand von Geberunterkante bis zum Tankboden: 4 mm  
Minimum distance from lower edge of sensor to tank floor: 4 mm

(H): Geber-Einbautiefe  
Sensor insertion length

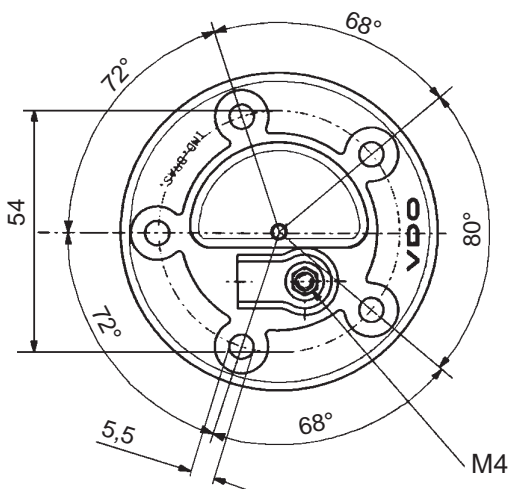

Anschlussart / Type of Connection:

Mit den im Lieferumfang enthaltenen zwei Flachsteckern 6,3 x 0,8 mm sind folgende Konfigurationen der elektrischen Anschlüsse möglich:

With the two 6.3 x 0.8 mm spade connectors included in delivery the following configurations of the electric connections are possible:

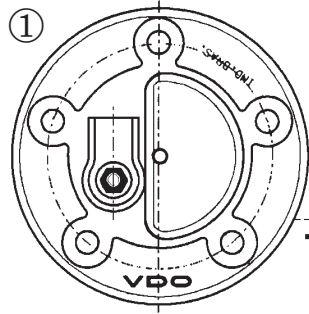

M4 für Signalausgang ohne Masseanschluss / Threaded stud M4 for signal output without ground connection

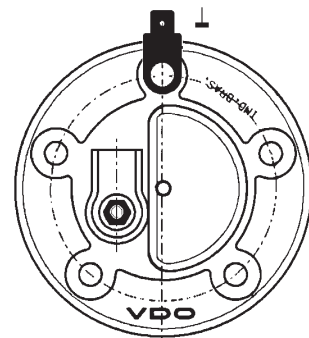

M4 für Signalausgang und Flachstecker für Masseanschluss / Threaded stud M4 for signal output and spade connector for ground connection

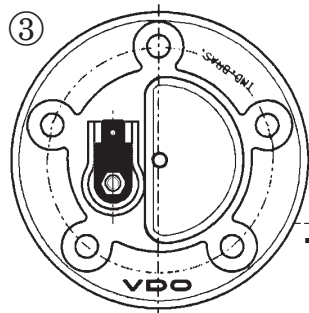

Flachstecker für Signalausgang ohne Masseanschluss / Spade connector for signal output without ground connection

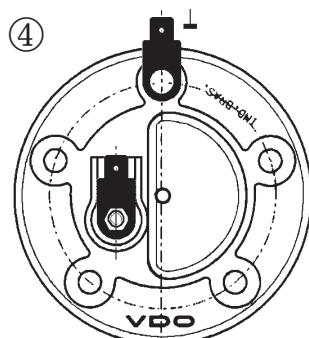

Flachstecker für Signalausgang und Flachstecker für Masseanschluss / Spade connector for signal output and spade connector for ground connection

**Kraftstoff-Tauchrohrgeber  
Metall Standard  
Flanschlochkreis Ø 54 mm**

**Tubular Fuel Level Sensor  
Metal Standard  
Flange bolt hole circle dia. 54 mm**

Artikelnummer Order Number	H [mm]	Stützfeder Support spring	Elektrischer Anschluss** Electrical connection**	Masseanschluss Ground connection
224-011-000-150G/X	150.0	nein / No	1/2	Optional
224-011-000-160G/X	160.0	nein / No	1/2	Optional
224-011-000-170G/X	170.0	nein / No	1/2	Optional
224-011-000-180G/X	180.0	nein / No	1/2	Optional
224-011-000-190G/X	190.0	nein / No	1/2	Optional
224-011-000-200G/X	200.0	nein / No	1/2	Optional
224-011-000-210G/X	210.0	nein / No	1/2	Optional
224-011-000-220G/X	220.0	nein / No	1/2	Optional
224-011-020-221G/X	221.0	nein / No	2	nein / No
224-011-000-230G/X	230.0	nein / No	1/2	Optional
224-011-000-240G/X	240.0	nein / No	1/2	Optional
224-011-000-250G/X	250.0	nein / No	1/2	Optional
224-011-010-251G/X	251.0	nein / No	3	nein / No
224-011-000-260G/X	260.0	nein / No	1/2	Optional
224-011-000-270G/X	270.0	nein / No	1/2	Optional
224-011-020-279G/X	279.0	nein / No	2	nein / No
224-011-000-280G/X	280.0	nein / No	1/2	Optional
224-011-000-290G/X	290.0	nein / No	1/2	Optional
224-011-020-292G/X	292.0	nein / No	2	nein / No
224-011-000-300G/X	300.0	nein / No	1/2	Optional
224-011-000-310G/X	310.0	nein / No	1/2	Optional
224-011-010-311G/X	311.0	nein / No	3	nein / No
224-011-000-320G/X	320.0	nein / No	1/2	Optional
224-011-000-330G/X	330.0	nein / No	1/2	Optional
224-011-000-340G/X	340.0	nein / No	1/2	Optional
224-011-010-341G/X	341.5	nein / No	3	nein / No
224-011-010-345G/X	345.0	nein / No	3	nein / No
224-011-000-350G/X	350.0	nein / No	1/2	Optional
224-011-000-360G/X	360.0	nein / No	1/2	Optional
224-011-000-370G/X	370.0	nein / No	1/2	Optional
224-011-010-372G/X	372.0	nein / No	3	nein / No
224-011-020-372G/X	372.0	nein / No	2	nein / No
224-011-000-380G/X	380.0	nein / No	1/2	Optional
224-011-000-390G/X	390.0	nein / No	1/2	Optional
224-011-000-400G/X	400.0	nein / No	1/2	Optional
224-011-010-404G/X	404.0	nein / No	3	nein / No
224-011-010-433G/X	433.0	nein / No	3	nein / No
224-011-110-442G/X	442.0	ja / Yes	3	nein / No
224-011-000-450G/X	450.0	nein / No	1/2	Optional
224-011-010-463G/X	463.0	nein / No	3	nein / No
224-011-010-478G/X	478.0	nein / No	3	nein / No
224-011-110-498G/X	498.0	ja / Yes	3	nein / No
224-011-000-500G/X	500.0	nein / No	1/2	Optional
224-011-022-521G/X	521.0	nein / No	2	ja / Yes
224-011-000-550G/X	550.0	nein / No	1/2	Optional
224-011-010-590G/X	590.0	nein / No	3	nein / No
224-011-022-590G/X	590.0	nein / No	2	ja / Yes
224-011-120-596G/X	596.0	ja / Yes	2	nein / No
224-011-000-600G/X	600.0	nein / No	1/2	Optional
224-011-010-613G/X	613.5	nein / No	3	nein / No

**Kraftstoff-Tauchrohrgeber  
Metall Standard  
Flanschlochkreis Ø 54 mm**

**Tubular Fuel Level Sensor  
Metal Standard  
Flange bolt hole circle dia. 54 mm**

Artikelnummer Order Number	H [mm]	Stützfeder Support spring	Elektrischer Anschluss** Electrical connection**	Masseanschluss Ground connection
224-011-110-634G/X	634.0	ja / Yes	3	nein / No
224-011-000-650G/X	650.0	nein / No	1/2	Optional
224-011-110-650G/X	650.0	ja / Yes	3	nein / No
224-011-110-664G/X	664.0	ja / Yes	3	nein / No
224-011-010-691G/X	691.5	nein / No	3	nein / No
224-011-000-700G/X	700.0	nein / No	1/2	Optional
224-011-000-750G/X	750.0	nein / No	1/2	Optional
224-011-010-786G/X	786.0	nein / No	3	nein / No
224-011-000-800G/X	800.0	nein / No	1/2	Optional
224-011-110-810G/X	810.0	ja / Yes	3	nein / No
** 1 Anschlussmutter, 2 Flachstecker, 3 Sechskantmutter / 1 Terminal nut, 2 Blade connector, 3 Hexagonal nut Verpackungsbuchstabe G: Einzelverpackung / Part number Extension G: Single Packaging Verpackungsbuchstabe X: Mehrfachverpackung / Part number Extension X: Multiple Packaging				

**Zubehör / Accessories:**

Artikelnummer / Order Number	Beschreibung / Description
890-225-012	Kork-Gummi-Dichtung Ø 66,5 x 4,5 mm / Seal (Cork Rubber) dia. 66.5 x 4.5 mm
2-250-234	Kork-Dichtung Ø 66,5 x 4,5 mm / Seal (Cork) dia. 66.5 x 4.5 mm
2-251-243	Gummi-Dichtung Ø 65,0 x 2,7 mm / Seal (Rubber) dia. 65.0 x 2.7 mm
2-250-264-1241	Flansch, verzinkt, blau passiviert / Flange, zinc plated, blue passivated

Weitere Längenvarianten können ab einem Jahresbedarf von 2000 Stück festgelegt werden.  
 Hierzu benutzen Sie bitte das Sensor Questionnaire.  
 Further length variants can be defined from a yearly requirement of 2000 parts on.  
 On this, please use the sensor questionnaire.

**Kraftstoff-Tauchrohrgeber**  
**Metall Robust**  
**Flanschlochkreis Ø 80 mm**

**Tubular Fuel Level Sensor**  
**Metal Robust**  
**Flange bolt hole circle dia. 80 mm**

Abmaße / Dimensions (mm):

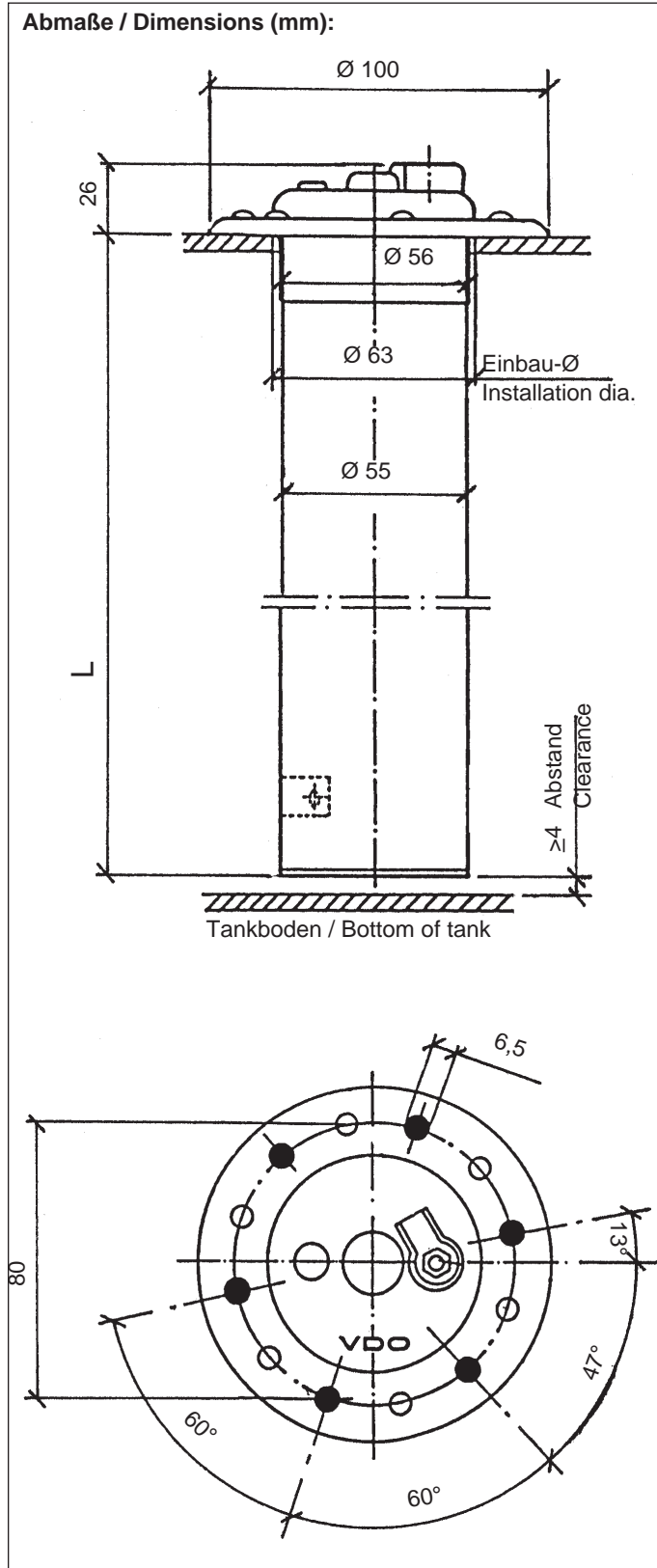

Sonderheiten:

(gehören nicht grundsätzlich zum Lieferumfang)

Special features: (not principally available)

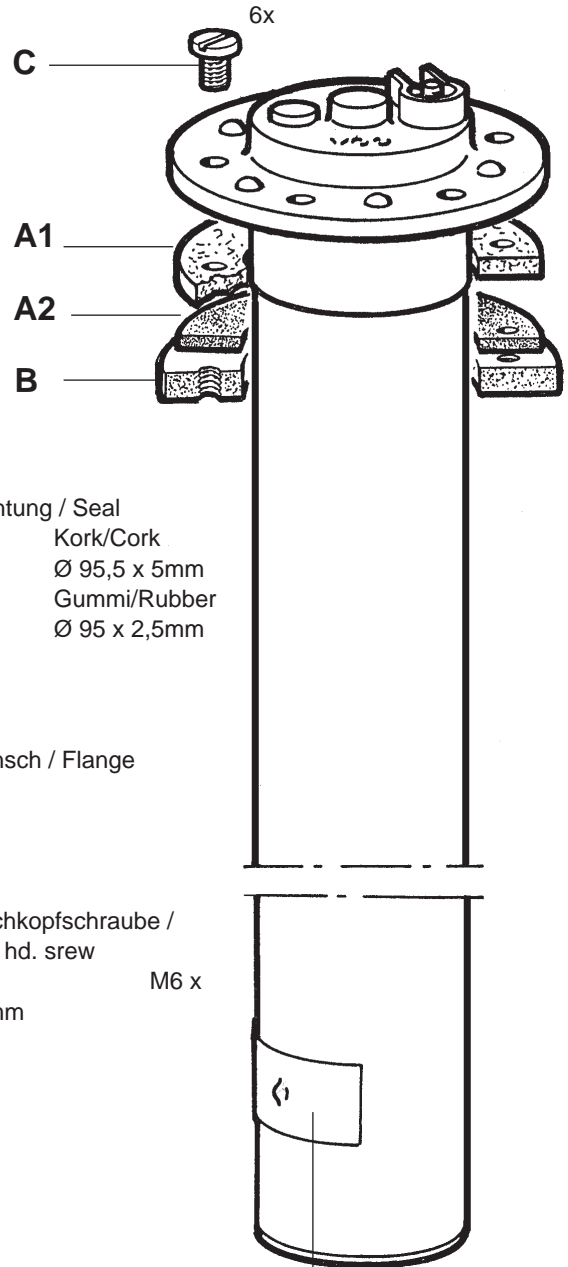

**A**

Dichtung / Seal

A1 Kork/Cork

$\text{Ø } 95,5 \times 5\text{mm}$

A2 Gummi/Rubber

$\text{Ø } 95 \times 2,5\text{mm}$

**B**

Flansch / Flange

**C**

Flachkopfschraube /  
Flat hd. screw

M6 x

10mm

Vor Montage Klebeband und  
Stift entfernen /  
Before installation, remove  
adhesive tape and pin.

**Kraftstoff-Tauchrohrgeber**  
**Metall Robust**  
**Flanschlochkreis Ø 80 mm**

**Anschlussart:**

**Tubular Fuel Level Sensor**  
**Metal Robust**  
**Flange bolt hole circle dia. 80 mm**

**Type of Connection:**

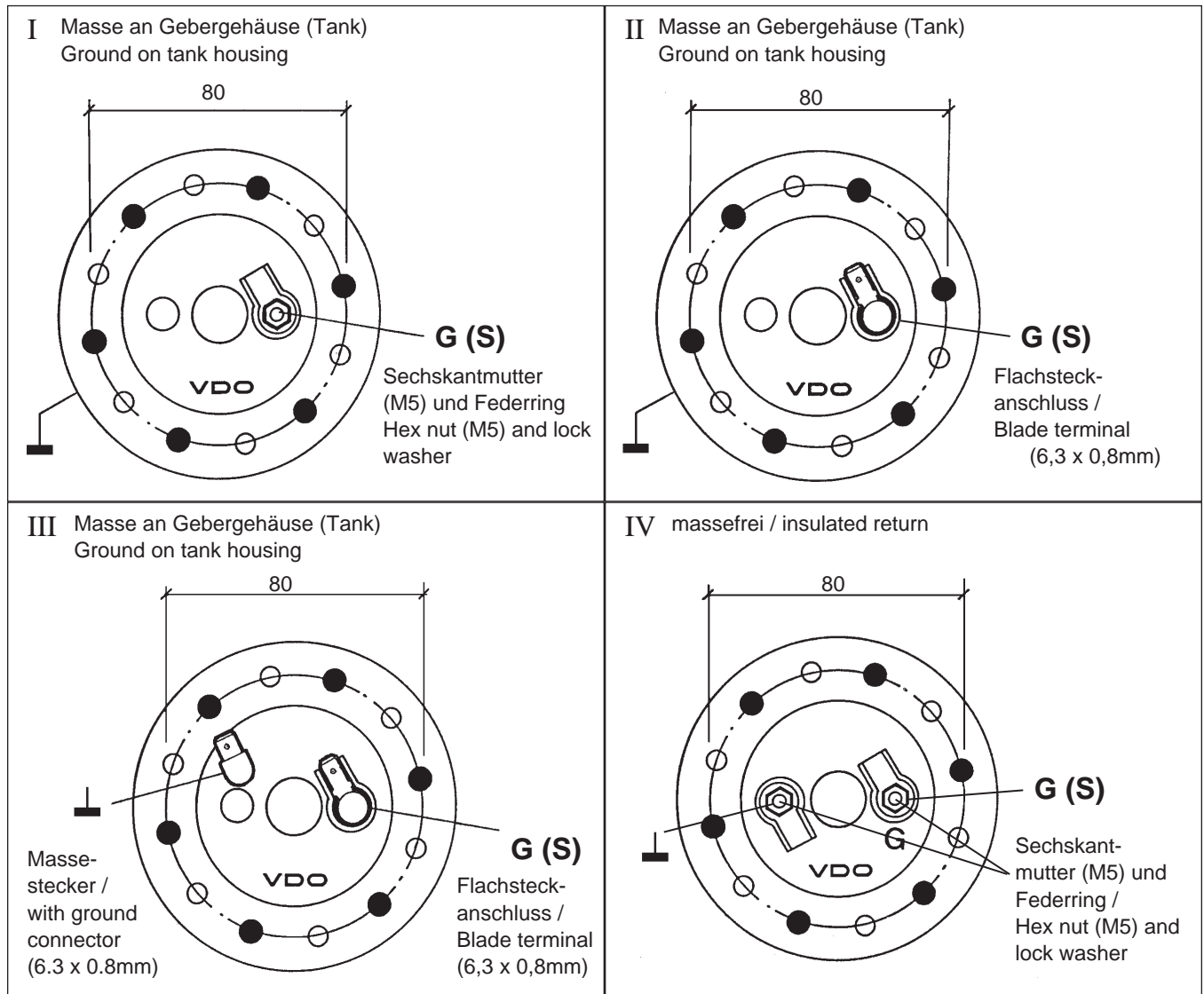

**Technische Daten:**

Nennspannung: 6 V bis 24 V  
 Betriebstemperatur: - 25 °C bis + 70 °C  
 Einbau von oben

**Technical Data:**

Rated voltage: 6 V to 24 V  
 Operating temperature: - 25 °C to + 70 °C  
 Installation from above

**Kraftstoff-Tauchrohrgeber**  
**Metall Robust**  
**Flanschlochkreis Ø 80 mm**

**Tubular Fuel Level Sensor**  
**Metal Robust**  
**Flange bolt hole circle dia. 80 mm**

Artikelnummer Order Number	Einbautiefe L Installation depth L [mm]	Widerstandswerte / Schwimmeranschlag Resistance / float limit stop		Art Type	Sonderheit Special feature
		oben / Top [Ω]	unten / Bottom [Ω]		
X10-224-014-031 ★	326	1.5 ±0.4	59.4 ±1.2	III	A2
X10-224-014-030 ★	380	2.2 ±0.4	88.5 ±1.8	III	A2
X10-224-014-036 ★	500	1.0 ±0.4	63.3 ±1.4	III	A2
X10-224-009-037	536	0.8 ±0.4	67.2 ±1.4	I	–
X10-224-021-001 ★	536	1.0 ±0.4	67.9 ±1.4	IV	A1
X10-224-009-053 ★	551	0.8 ±0.4	69.3 ±1.4	I	A1
X10-224-009-039 ★	596	1.3 ±0.4	75.0 ±1.6	I	A2
X10-224-021-002 ★	596	1.0 ±0.4	75.7 ±1.6	IV	A1
X10-224-014-022 ★	616	1.0 ±0.4	78.3 ±1.6	II	A2
X10-224-009-048	641	0.8 ±0.4	81.0 ±1.8	I	A1
X10-224-014-014 ★	671	0.7 ±0.4	59.2 ±1.3	II	A2
X10-224-014-002	686	0.8 ±0.4	86.7 ±1.8	III	–
X10-224-009-016 ★	716	0.6 ±0.4	69.7 ±1.4	I	A2, B
X10-224-009-029	741	0.5 ±0.4	65.0 ±1.4	I	A2, B, C
X10-224-009-019	781	0.5 ±0.4	68.7 ±1.4	I	A2
X10-224-021-004	803	0.7 ±0.4	71.1 ±1.6	IV	A1
X10-224-009-026	831	0.6 ±0.4	82.8 ±1.8	I	A2, B, C
X10-224-021-006	846	0.7 ±0.4	75.0 ±1.6	IV	A1
X10-224-014-003	881	0.7 ±0.4	78.0 ±1.6	II	–
X10-224-014-011	916	0.7 ±0.4	81.2 ±1.8	II	A2
X10-224-014-023 ★	946	0.7 ±0.7	83.9 ±2.5	II	A1
X10-224-014-015 ★	996	0.5 ±0.4	59.0 ±1.2	II	A2
X10-224-009-022 ★	1,001	0.5 ±0.4	88.4 ±1.8	I	A2, B, C
X10-224-009-021 ★	1,045	0.5 ±0.4	92.5 ±2.0	I	A2, B, C
X10-224-021-005 ★	1,045	0.7 ±0.4	92.9 ±2.0	IV	A1
X10-224-009-040	1,086	0.4 ±0.4	64.0 ±1.4	I	A2, B
X10-224-014-044 ★	1,250	0.5 ±0.4	74.2 ±1.6	II	A2
X10-224-009-072 ★	1,387	0.5 ±0.4	82.4 ±1.8	I	A2, B, C

★ Auslauf, bitte Verfügbarkeit prüfen. / Phase out, please check availability.

Artikelnummer / Order Number	Beschreibung / Description
2-251-006	Kork-Dichtung Ø 95,5 x 5,0 mm / Seal (Cork) dia. 95.5 x 5.0 mm
2-251-016	Gummi-Dichtung Ø 95,0 x 2,5 mm / Seal (Rubber) dia. 95.0 x 2.5 mm
11-591-001-1401	Flansch, vermessingt / Flange, brass plated



# Datenblätter für Kraftstoff-Tauchrohrgeber / Data Sheets For Tubular Fuel Level Sensors

## Änderungsübersicht / Change Overview

Datum Date	Produktgruppe / Product line Doku-Nr. / Documentation No.	Seite Page	Bemerkung Comment
0812	Kraftstoff-Tauchrohrgeber / Tubular fuel Level Sender	1-2	Komplette Neuausgabe / Complete revision

VDO – a Trademark of the Continental Corporation

Technische Änderungen vorbehalten | Technical details subject to change

TU00-0772-7004620 | 0812 |